

25 W Dimmable DALI LED driver

25 W 220 – 240 V 0/ 50 – 60 Hz

- SELV output protection for safety and flexibility in luminaires
- DALI control input, 1-100 % dimming range
- Suitable for use in emergency lighting applications
- Long lifetime up to 100 000 h
- Driver protection Class II
- Suitable for Class I and Class II luminaires
- Optional strain relief for independent use outside of luminaire (LC1x30-SR) and driving Class III (SELV) luminaires

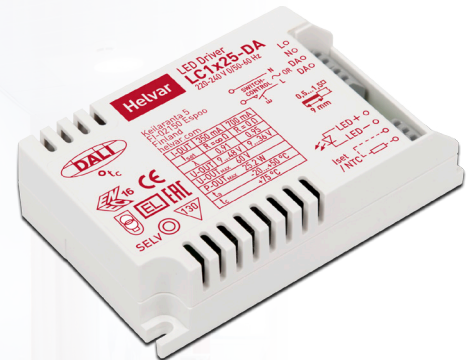

Functional Description

- Adjustable constant current output: 350 mA (default) to 700 mA
- Current setting programmable by Helvar driver configurator, by DALI commands or by external resistors
- Hybrid dimming technique for high quality light
- Switch-Control functionality for easy-to-use intensity control
- Adaptive LED overload protection. Reduces output current if overload is detected
- Full load recognition, open and short circuit protection
- Multipurpose terminal Iset/NTC for current setting or over temperature protection
- Constant Light Output (CLO) (default disabled)
- Power consumption monitor (real time), Running hour monitor (accumulative), Energy management (accumulative)

Mains Characteristics

Voltage range	198 VAC – 264 VAC
DC range	176 VDC - 280 VDC
starting voltage	> 190 VDC
Mains current at full load	0.13 A – 0.14 A
Frequency	0 / 50 Hz – 60 Hz
Stand-by power consumption	< 0.45 W
THD at full power	< 20 %
Leakage current to earth	< 0.5 mA
Tested surge protection	1 kV L-N, 2 kV L-GND (IEC 61000-4-5)
Tested fast transient protection	4 kV (IEC 61000-4-4)

Insulation between circuits & driver case

Mains circuit - SELV circuit	Double/reinforced insulation
DALI circuit - SELV circuit	Double/reinforced insulation
Mains circuit - DALI circuit	Basic insulation
Mains and output - Driver case	Double/reinforced insulation

Load Output (SELV <60 V)

Output current (I_{out})	350 mA (default) – 700 mA
Accuracy	± 5 %
Ripple	< 2 %* at ≤ 120 Hz
*] Low frequency, LED load: Cree XM-L LEDs	
U_{out} (max) (abnormal)	60 V
EOfx (EL use)	> 0.98

	350 mA	700 mA
I_{out}	350 mA	700 mA
P_{out} (max)	16.8 W	25.2 W
U_{out}	9 V – 48 V	9 V – 36 V
PF (λ) at full power	0.91	0.95
Efficiency (η), full load	85 %	86 %

Operating window

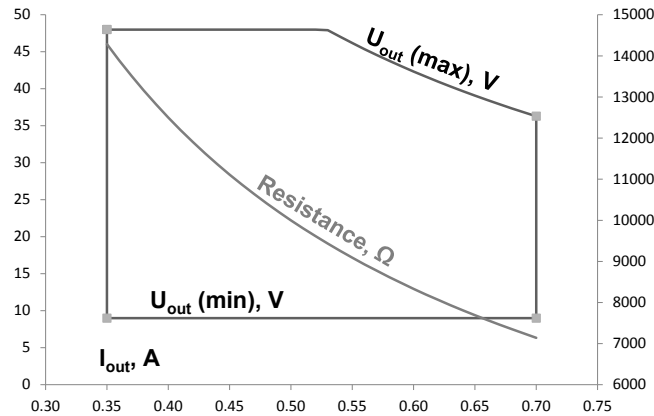

Note: Dimming between 1% - 100% possible across the whole operating window

Hybrid dimming technique

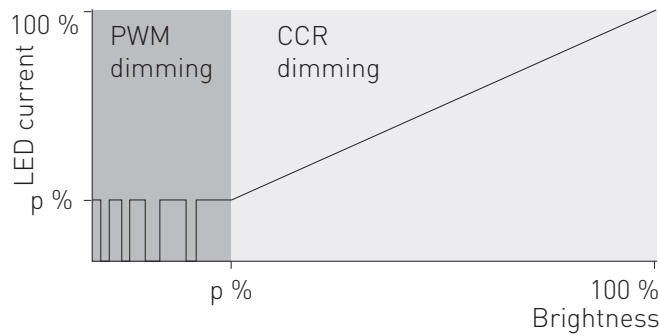

Dimming range	Dimming technique
1% - 22%	Pulse Width Modulation (PWM)*
22% - 100%	Constant Current Reduction (CCR)

* PWM dimming frequency 800 Hz

Driver performance

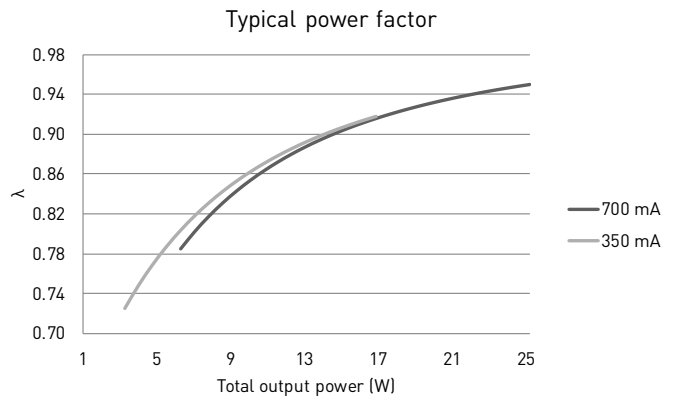
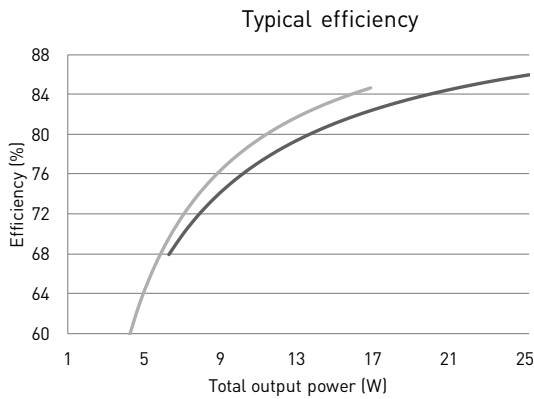

Operating Conditions and Characteristics

- Highest allowed t_c point temperature: 75 °C
- Ambient temperature range: -20 °C ... +50 °C
- Storage temperature range: -40 °C ... +80 °C
- Maximum relative humidity: No condensation
- Life time (90 % survival rate):
 - 100 000 h, at $t_c = 65$ °C
 - 90 000 h, at $t_c = 70$ °C
 - 60 000 h, at $t_c = 75$ °C

Quantity of drivers per miniature circuit breaker 16 A Type C

Based on I_{cont}	Based on inrush current I_{peak}	Typ. peak inrush current I_{peak}	1/2 value time, Δt	Calculated energy, $I_{peak}^2 \Delta t$
86 pcs.	86 pcs.	24 A	115 μs	0.048 A ² s

Connections and Mechanical Data

Wire size	0.5 mm ² – 1.5 mm ²
Wire type	Solid core and fine-stranded
Wire insulation	According to EN 60598
Maximum driver to LED wire length	5 m
Weight	135 g
IP rating	IP20

Connections

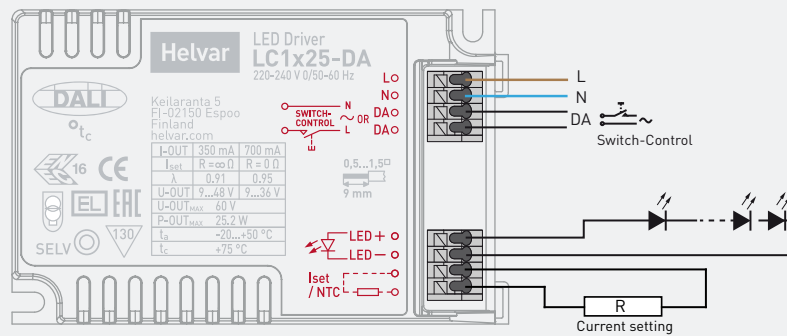

Note:

- Not suitable for load side switching operation
- Label may differ if the unit is preset to fixed current

Available Iset resistor values (Nominal I_{out} (±5 % tol.))

Resistor (Ω)	0	7680	8250	9090	10k	11k	12k4	Open
I _{out} (mA)	700	651	606	550	500	454	403	350
SAP code	T70000	T77681	T78251	T79091	T70103	T70113	T71242	N/A

Current setting resistor values, E48 series (Nominal I_{out} (±5 % tol.))

Resistor (Ω)	0	7500	7870	8250	8660	9090	9530	10k	10k5	11k	11k5	12k1	12k7	13k3	Open
I _{out} (mA)	700	667	635	606	577	550	525	500	476	454	435	413	394	376	350

Dimensions (mm)

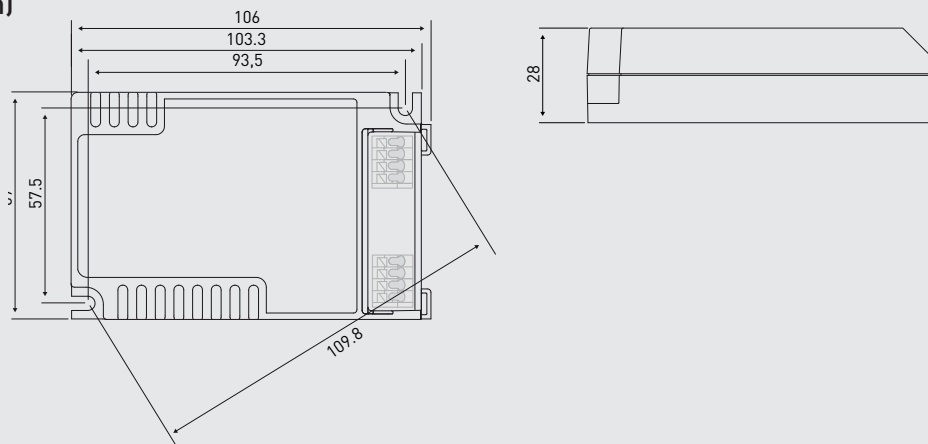

LC1x25-DA LED driver is suited for built-in usage in luminaires. In order to have safe and reliable LED driver operation, the LED luminaires will need to comply with the relevant standards and regulations (e.g. IEC/EN 60598-1). The LED luminaire shall be designed to adequately protect the LED driver from dust, moisture and pollution. The luminaire manufacturer is responsible for the correct choice and installation of the LED drivers according to the application and product datasheets. Operating conditions of the LED driver may never exceed the specifications as per the product datasheet.

Installation & operation

Maximum t_c temperature:

- Reliable operation and lifetime is only guaranteed if the maximum t_c point temperature is not exceeded under the conditions of use
- Ensure that the t_c point temperature does not rise higher than specified on the product datasheets

Installation site:

- The general preferred installation position of LED drivers for independent use is to have the top cover facing upwards

Current setting resistor

LC1x25-DA LED driver features an adjustable constant current output.

- An external resistor can be inserted in to the current setting terminal, allowing the user to adjust the LED driver output current
- When no external resistor is connected, then the LED drivers will operate at their default lowest current level
- A standard through-hole resistor can be used for the current setting. To achieve the most accurate output current it is recommended to select a quality low tolerance resistor. Minimum diameter for resistor leg is 0.51mm
- Resistor/current values follow LEDset specification for current setting and are presented on page 3

Lamp failure functionality

No load

When open load is detected, driver will go to standby. Automatic recovery is on during the first 10 minutes. If open load is still detected after the first 10 minutes, driver goes to standby mode and recovers through mains reset.

Short circuit

When short circuit is detected, driver goes to standby mode and returns through mains reset.

Overload

When high over load is detected, driver goes to standby mode and follows the same logic as described in the short circuit condition. When low over load is detected, output current will be reduced to have maximum rated output power.

Underload

When under voltage is detected, driver goes to standby mode and returns through mains reset.

Conformity & standards

General and safety requirements	EN 61347-1: 2008+ A1:2011+A2:2013
Particular safety requirements for DC or AC supplied electronic control gear for LED modules	EN 61347-2-13: 2014
Additional safety requirements for DC or AC supplied electronic control gear for LED modules	EN 61347-2-13: 2014, Annex J
Thermal protection class	EN 61347, C5e
Mains current harmonics	EN 61000-3-2: 2014
Limits for voltage fluctuations and flicker	EN 61000-3-3: 2013
Radio frequency interference	EN 55015: 2013
Immunity standard	EN 61547: 2009
Performance requirements	EN 62384: 2006+ A1:2009
Digital addressing lighting interface:	
General requirements for DALI system	EN 62386-101
Requirements for DALI control gear	EN 62386-102
Requirements for control gear of LED modules (DALI Device Type 6)	EN 62386-207
Independent usage acc. to relevant clauses of	EN 60598-1 : 2015
Compliant with relevant EU directives	
RoHS / REACH compliant	
ENEC and CE marked	

Label symbols

- AC/DC supplied electronic control gear for emergency lighting purposes intended for connection to a centralized emergency power supply.
- Safety isolating control gear with short circuit protection (SELV control gear).
- Double insulated control gear suitable for built-in use.
- Thermally controlled control gear, incorporating means of protection against overheating to prevent the case temperature under any conditions of use from exceeding 130 °C.